

Schematic Eyes - Introduction

- Curvatures, spacings and indices of the ocular components lead us to raytracing the surfaces to determine the imaging properties of the eye.
- Many schematic eye models exist of varying complexity.
- Cardinal points are a first priority, aberration analysis is a more sophisticated analysis.

Gullstrand-LeGrand Eye Model

		Anterior Cornea	Posterior Cornea	Anterior Lens	Posterior Lens	Retina
R (mm)		7.8	6.5	10.2	-6	-13.4
ϕ (mm ⁻¹)		-0.04835	0.006108	-0.0081	-0.014	
t (mm)	Infinity	0.55	3.05	4		16.59655
n	1	1.3771	1.3374	1.42		1.336
t/n (mm)		0.39939	2.280544	2.816901		12.42257
y (mm)		1	0.980691	0.884095	0.744614	0
nu (rad)	0	-0.04835	-0.04236	-0.04952	-0.05994	
yc (mm)		-0.30376	-0.25796	0	0.31862	1.668325
nuc (rad)	0.1	0.114686	0.11311	0.11311	0.108649	

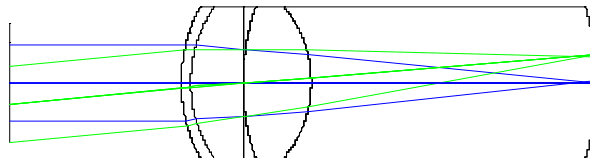

Cardinal Points & Pupils

- Principal Planes – conjugate planes that have unit magnification. Can be used to generate effective lens.
- Focal Points – points where collimated beams come to focus.
- Nodal Points – a ray passing through the front nodal point at a given angle, leaves the rear nodal point at the same angle.
- Entrance and Exit pupils – conjugate planes that are the entrance and exit ports of the optical system.

Principal Planes

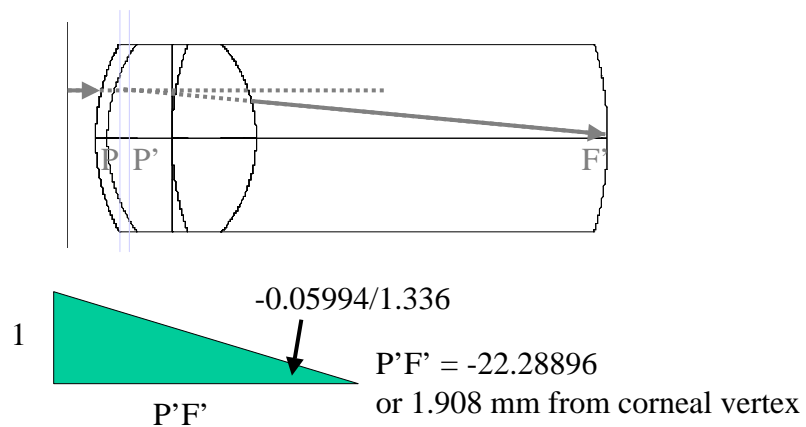

Similarly, the front principal plane P is located 1.595 mm from corneal vertex.

Total Power

Total Power $\Phi = n' / P'F'$

$\Phi = 1.336 / 22.28896 \text{ mm} = 0.05994 \text{ mm}^{-1} = 59.94 \text{ D}$

Total Power $\Phi = 1 / PF$

$PF = -16.683 \text{ mm}$

or the front focal point is -15.089 mm from corneal vertex
(about where your spectacles sit).

Pupils

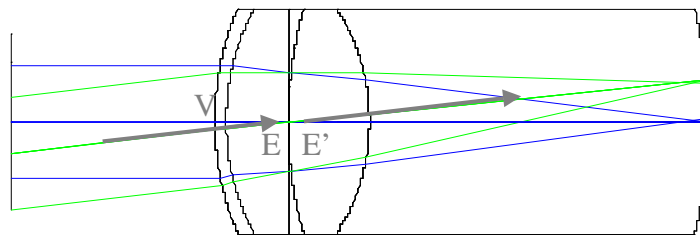

Entrance Pupil
VE
-0.30376
0.1
VE = 3.038 mm

Exit Pupil
0.108049/1.336
0.31862
VE' = 3.682 mm

Nodal Points

$$PN = P'N' = (n_{\text{vit}} - n_{\text{air}}) / \Phi = 0.336 / 0.05994 = 5.605 \text{ mm}$$

Front Nodal Point N is 7.200 mm from corneal vertex

Rear Nodal Point N' is 7.513 mm from corneal vertex

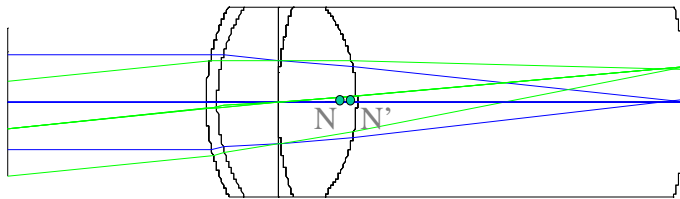

Angular Subtense

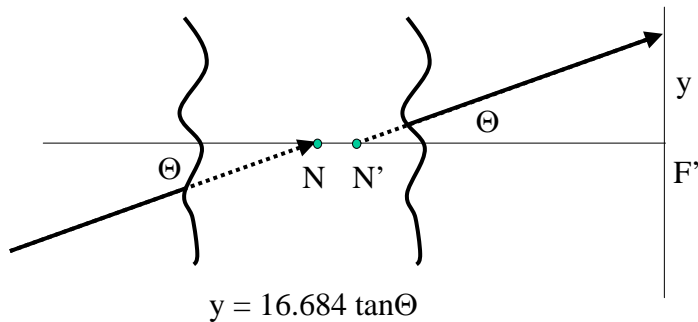

$$y = 16.684 \tan \Theta$$

Typically, 1 minute of arc is stated as the eye's limit of resolution. This leads to $y \sim 5$ microns (two points separated by 5 microns on the retina can just be resolved).

Accommodation



Relaxed ciliary muscle pulls zonules taut and flattens crystalline lens.

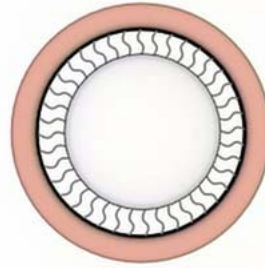

Constrict ciliary muscle releases tension on zonules and crystalline lens bulges.



Accommodated Gullstrand Model

	R (mm)	n	t' (mm)
Anterior Cornea	7.8	1.3771	.55
Posterior Cornea	6.5	1.3374	2.65
Anterior Lens	6.0	1.4270	4.50
Posterior Lens	-5.5	1.3360	16.497

Presbyopia

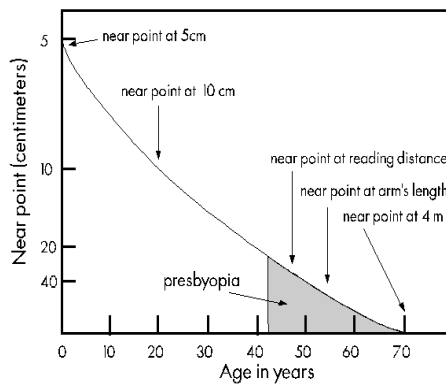

Your ability to accommodate reduces steadily with age. Typically, you don't notice the effects until it affects your ability to read comfortably. This is presbyopia.

Definitions – Refractive Error

- Myopia – near-sightedness. F' is in front of retina because eye is too long or power is too high

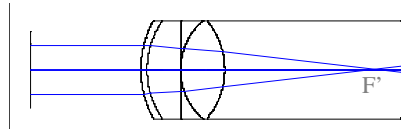

- Hyperopia – far-sightedness. F' is behind retina because eye is too short or power is too low.

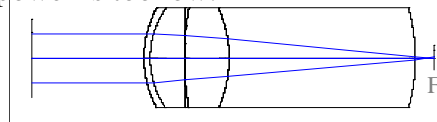

- Emmetropia – perfect vision. F' at retina.

Definitions

- Far Point – point conjugate to the retina when eye is unaccommodated.

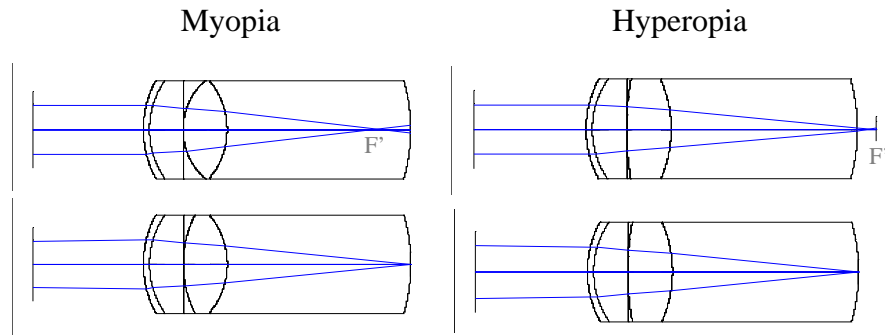

- Near point – point conjugate to the retina when the eye is fully accommodated.

Vergence

- Vergence is the measure of convergence or divergence of a pair of rays.
- Vergence is given in units of diopters (D) which is inverse distance in meters.
- Vergence is given by the refractive index divided by the distance from a plane of reference to the point where the rays intersect.
- Converging rays have positive vergence and diverging rays have negative vergence.
- Plane waves have zero vergence.

Vergence - Diverging Beam

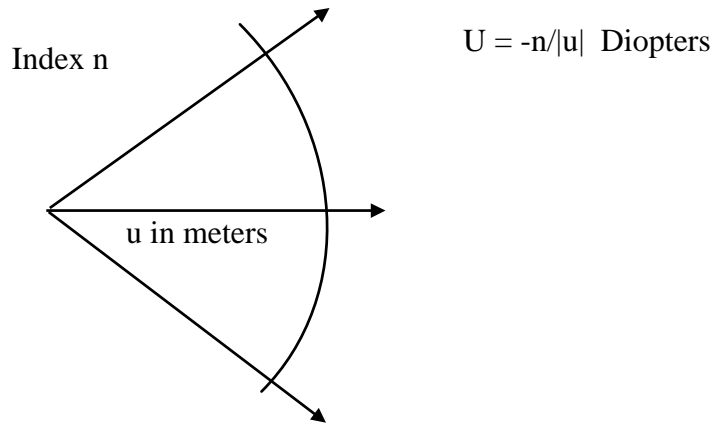

Vergence - Converging Beam

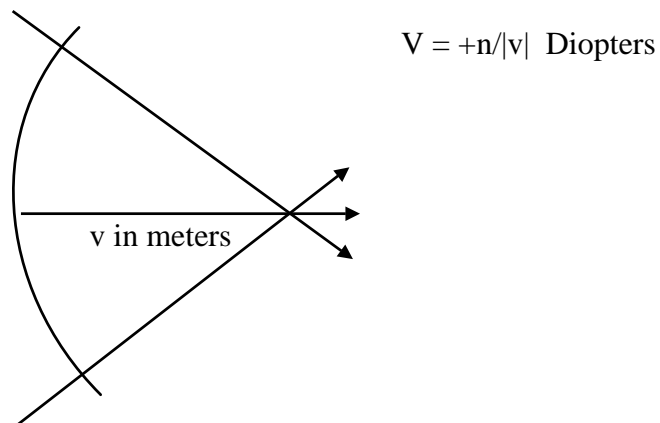

Vergence - Plane wave

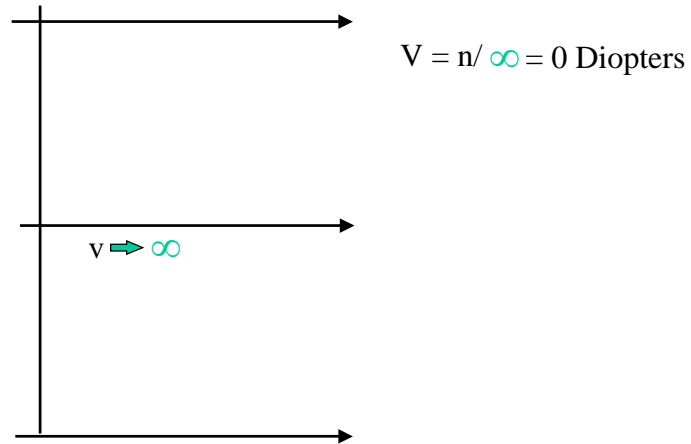

Lenses

- Lenses modify vergence such that $U+D=V$, where D is the power of the lens in diopters.

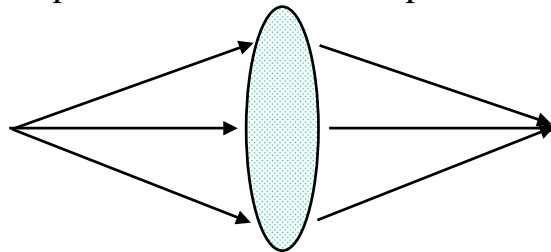

Accommodative Amplitude

- The amplitude of accommodation is the difference in vergence between the Far Point and the Near Point of the eye.
- For example, suppose the relaxed eye focuses at infinity and the fully accommodated eye focuses on an object 10 cm away, then

$$\text{Accommodative Amplitude} = A = \frac{1}{\infty} - \frac{-1}{0.1\text{m}} = 10\text{D}$$

Schematic Eye Models

- 1924 - Gullstrand made a six surface eye model (crystalline lens with a high index core and a lower index shell). Later reduced to four surfaces since raytracing is time consuming.
- 1952 - Emsley made a single surface model for simplicity and speed of raytracing. Today, computers can quickly raytrace eye models, so sophistication is ok.

Big Problem with early models is that the surfaces are all spherical. Therefore, the paraxial properties (Cardinal Points) are accurate, but aberrations do not look like clinical findings.

Schematic Eye Models

- 1971 - Lotmar (JOSA Vol 61, p. 1522) made anterior cornea a polynomial based on clinical measurements and made posterior lens a parabola to give clinical levels of spherical aberration.
- 1983 and 1985 - Kooijman (JOSA Vol 73, p. 1544) and Navarro (JOSA A Vol 2, p. 1273) Added aspherics to all four surfaces of their models. Kooijman model is based on light distribution on the retina. Navarro added dispersion for chromatic effects

Arizona Eye Model

Name	Radius	Conic	Index	Abbe	Thickness
	7.8 mm	-0.25			
Cornea	6.5 mm	-0.25	1.377	57.1	0.55 mm
Aqueous	R_{ant}	K_{ant}	1.337	61.3	t_{aq}
Lens	R_{post}	K_{post}	n_{lens}	51.9	t_{lens}
Vitreous	-13.4 mm	0.00	1.336	61.1	16.713 mm
Retina					

$$R_{ant} = 12.0 - 0.4A$$

$$R_{post} = -5.224557 + 0.2A$$

$$t_{aq} = 2.97 - 0.04A$$

$$n_{lens} = 1.42 + 0.00256A - 0.00022A^2$$

$$K_{ant} = -7.518749 + 1.285720A$$

$$K_{post} = -1.353971 - 0.431762A$$

$$t_{lens} = 3.767 + 0.04A$$

Conic Section

$$z = \frac{r^2 / R}{1 + \sqrt{1 - (K + 1) \frac{r^2}{R^2}}}$$

z = sag of surface

$r^2 = x^2 + y^2$

R = radius of curvature

K = conic constant

$K < -1$	Hyperboloid
$K = -1$	Paraboloid
$-1 < K < 0$	Prolate Spheroid (Ellipsoid)
$K = 0$	Sphere
$K > 0$	Oblate Spheroid (Ellipsoid)

Ellipsoids

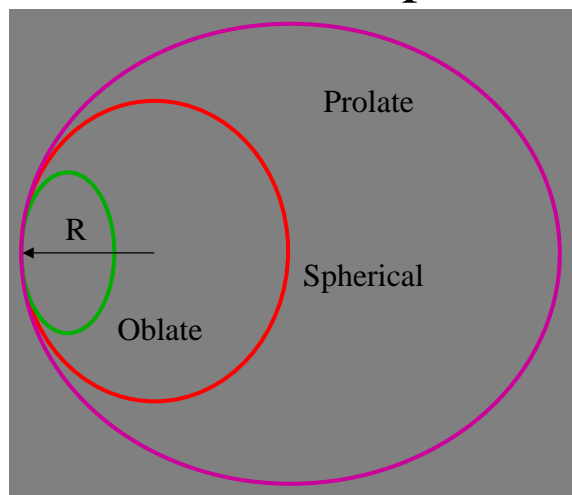

Cornea is prolate meaning that it flattens towards the periphery.

By adjusting the conic constant, the spherical aberration can be controlled without changing paraxial properties.

Conic Section (Alternatives)

$$z = \frac{1}{K+1} \left[R - \sqrt{R^2 - (K+1)r^2} \right] ; K \neq -1$$

$$z = \frac{r^2}{2R} ; K = -1$$

z = sag of surface
 $r^2 = x^2 + y^2$
 R = radius of curvature
 K = conic constant

Schematic Eyes - Spectral Sensitivity

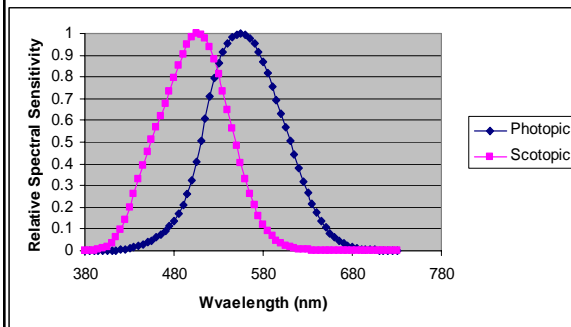

Scotopic - Low light level
Peak around 505 nm

Photopic - High light level
Peak around 555 nm

Mesopic - In between

To include in raytracing code, weight wavelengths by appropriate curve.

Stiles-Crawford Effect

- 1933 - Stiles and Crawford found an effect where light striking photoreceptors with a low angle of incidence has a higher efficiency than light striking at a high angle of incidence.

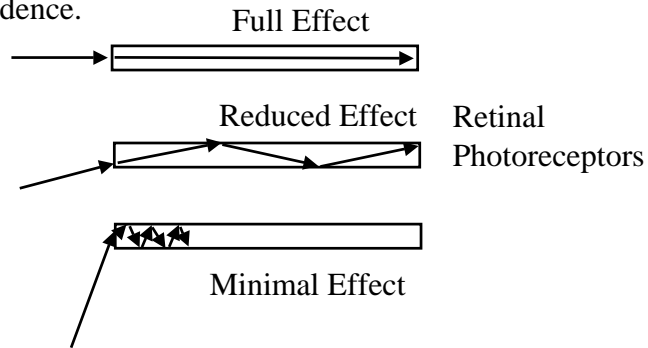

Schematic Eye Model

Reduce intensity of flickering beam until it is not detected.

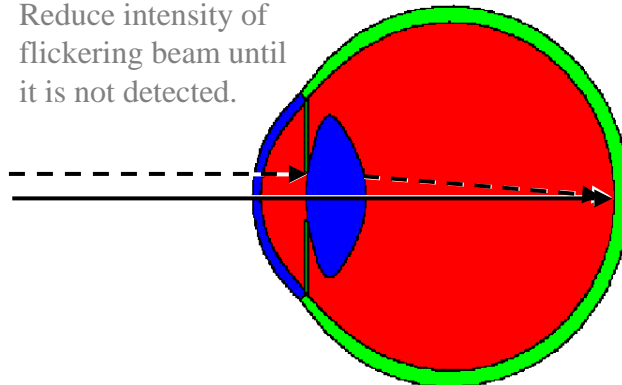

Stiles-Crawford Effect

The Stiles-Crawford effect acts like an apodizing filter.

Most raytracing problems allow for apodization.

Efficiency of peripheral ray fall to about 20% for 8 mm pupil.

$$L(r) = \exp(-0.105r^2)$$

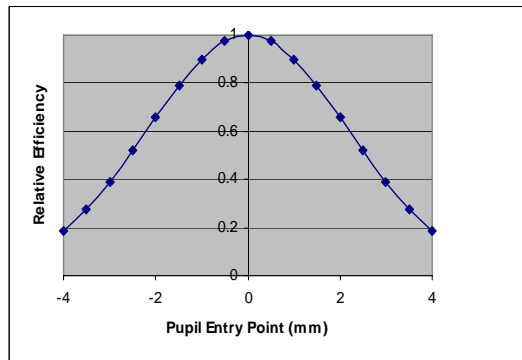

Apodization

Halo Reduction in Apodized Phase Contrast

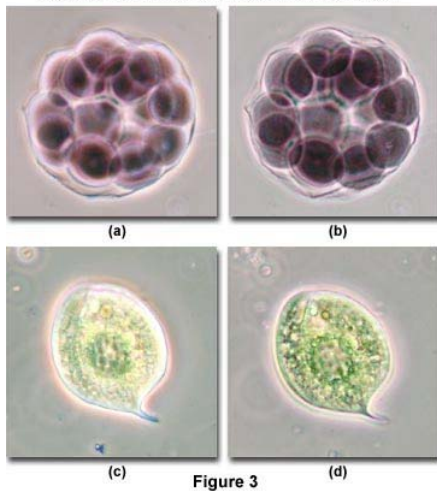
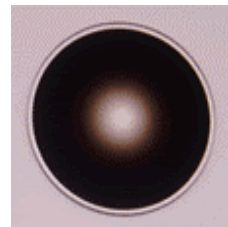

Figure 3

- Apodization is routinely used in microscopy and astronomy to reduce diffractive halos.



Astronomical Apodization

No Apodization

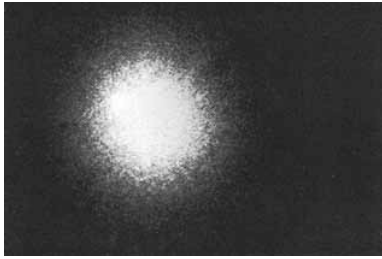

Sonine Apodization



A hexagonal apodizing filter is used in this case to shift the location of the diffracted light to reveal a stellar companion.

Stiles-Crawford Effect



The Stiles-Crawford effect is phototropic (i.e. the retinal photoreceptors realign themselves with the light source).

Eye Axes

Since the eye is not rotationally symmetric (i.e. the centers of curvature of each surface do not lie on a common axis), several axes can be defined which all collapse to the optical axis in rotationally symmetric systems.

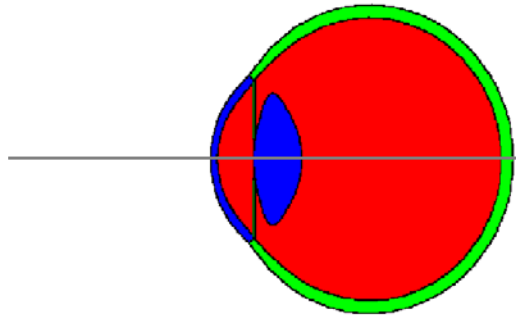

Visual Axis

The visual axis connects the fixation point to the front nodal and the rear nodal to the fovea. Usually denoted by angle α measured from optical axis. Typically $4^\circ \leq \alpha \leq 8^\circ$

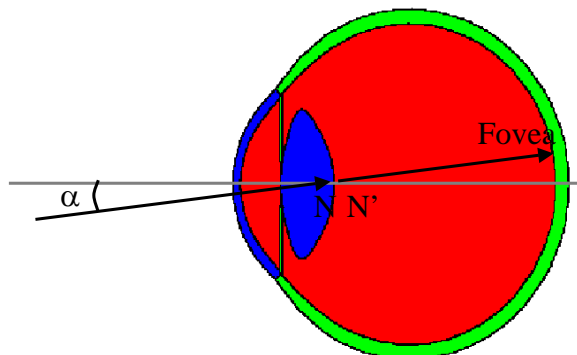

The fovea is usually displaced temporally and slightly inferior.

Pupillary Axis

The pupillary axis strikes the cornea at right angles and passes through the center of the entrance pupil. It is equivalent to the chief ray.

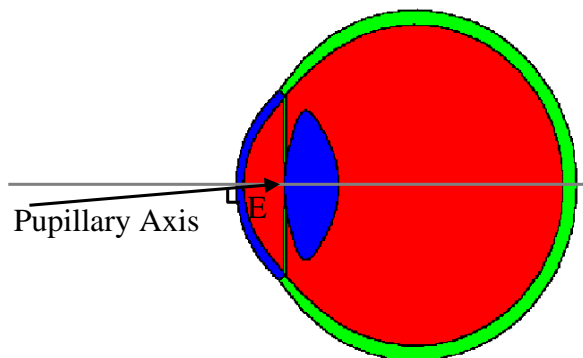

Line of Sight

The LOS connects the fixation point to the center of the entrance pupil and the center of the exit pupil to the fovea. Usually denoted by angle κ measured from pupillary axis. Typically $\kappa \leq \alpha$.

