

Section 5 – ISO 10110 Drawings

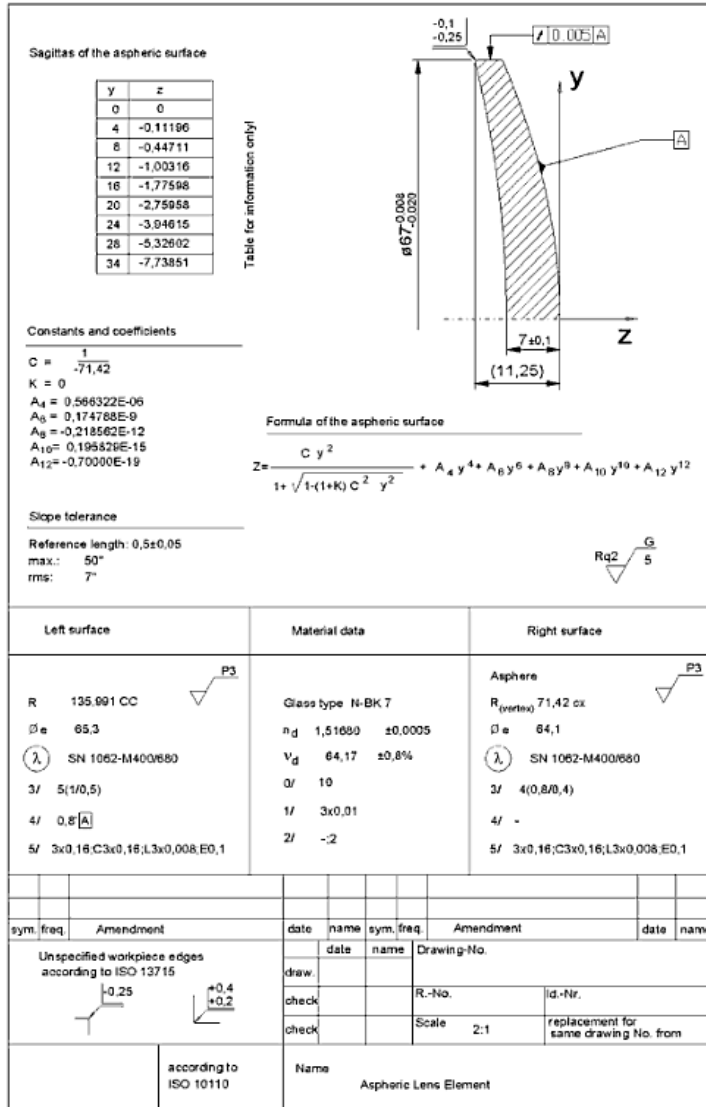

Optical Drawings provide a precise Definition of your optic for fabrication.

Standards allow for a common language to be used between you and the optician so there is no confusion regarding the features desired in the final part.

ISO 10110

Part	Title	Indication
1	General	N/A
2	Material imperfections – Stress birefringence	0/
3	Material imperfections – Bubbles and Inclusions	1/
4	Material Imperfections – Inhomogeneity and Striae	2/
5	Surface form tolerances	3/
6	Centering Tolerances	4/
7	Surface Imperfection tolerances	5/
8	Surface Texture	$\sqrt{\quad}$
9	Surface Treatment and coating	λ
10	Table representing data of a lens element	N/A
11	Non tolerance data	N/A
12	Aspheric surfaces	N/A
13	Laser irradiation damage threshold	6/

ISO 10110-1 General

- “Indications according to ISO 10110” appears on the drawing.
- The metric system for all linear dimensions is used, although the English system can be used as well, but needs to be indicated on the drawing. A comma is used instead of the decimal point.
- Standard language is English (UK). Note: centring instead of centering, colour instead of color, metre instead of meter.
- Anything described as “normative” in standard means “mandatory”.
- Reference wavelength = 546.07 nm Mercury e line.
- Temperature = $22 \pm 2^{\circ} \text{C}$

ISO 10110-1 Projection

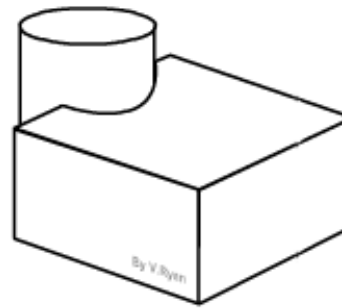

ISO 10110 Uses First Angle Projection. In US, Third Angle Projection is typically used.

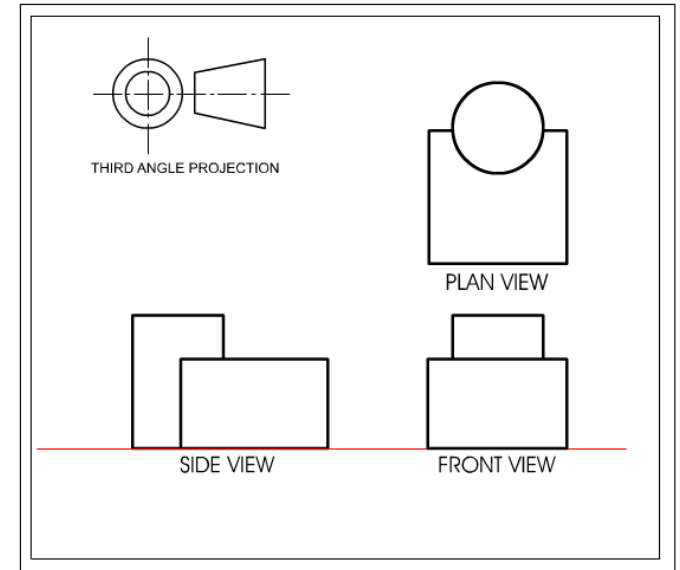
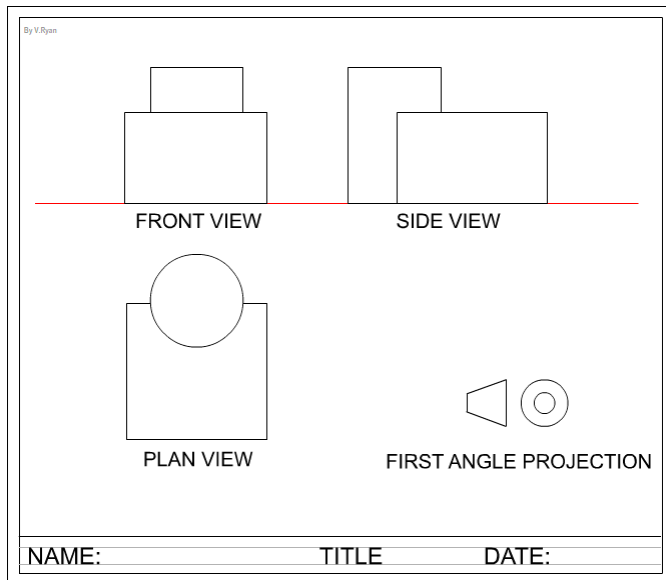

ISO 10110-1 Hatching

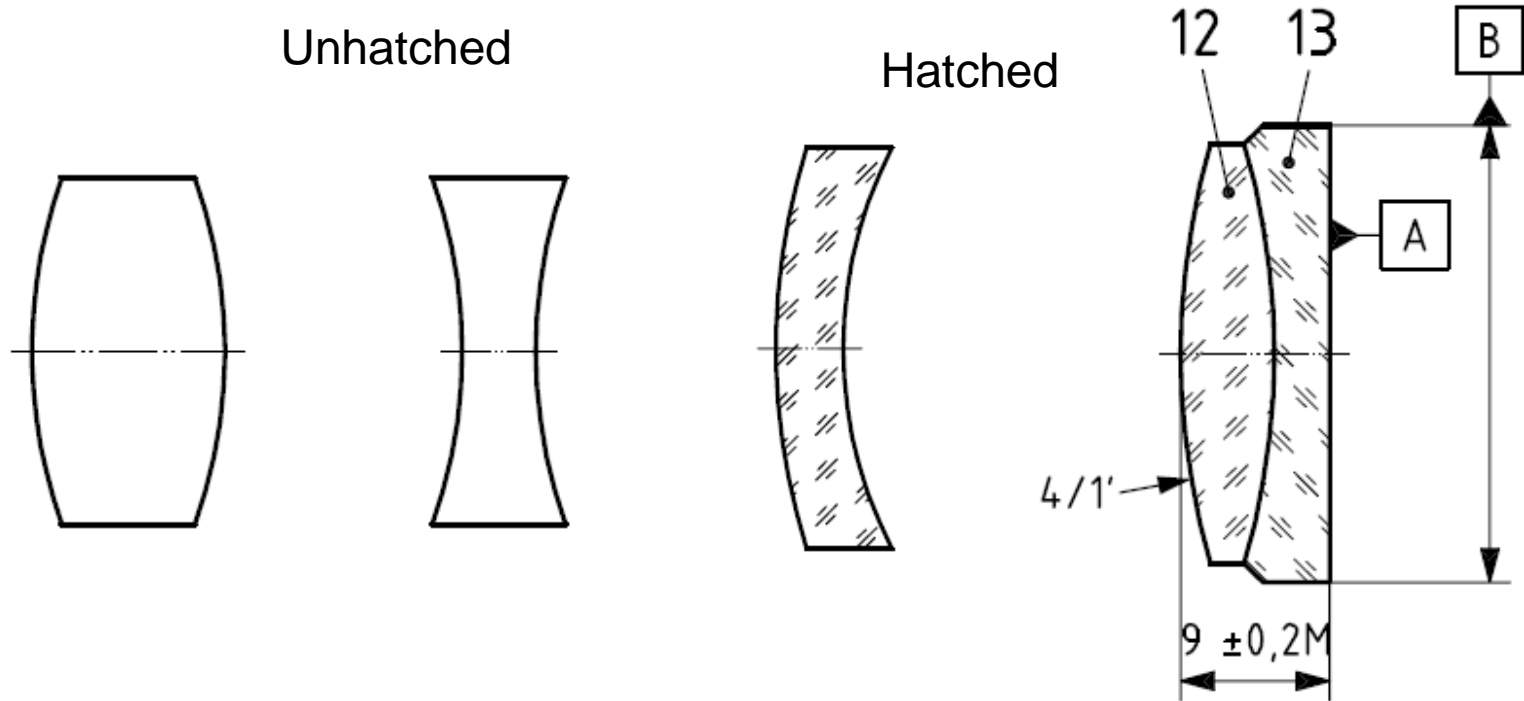

Optical Elements can be unhatched or have hatching (long line, with a short line on either side). Do not mix hatched and unhatched elements in same drawing. For multiple elements alternate orientation of hatching.

ISO 10110-1 Axes

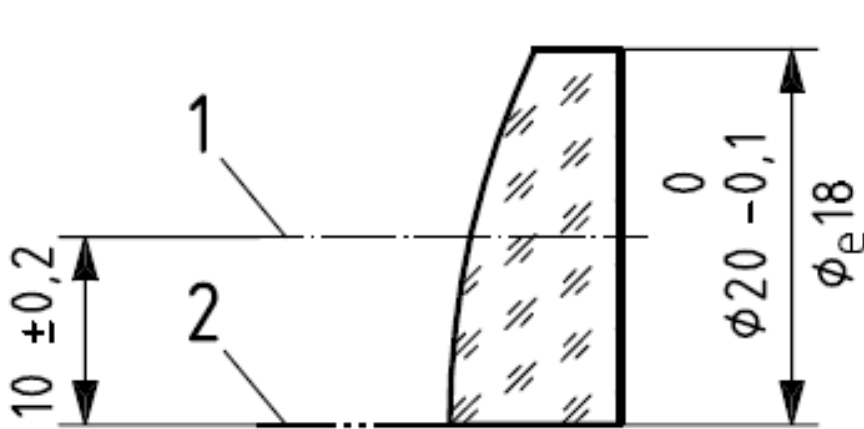

Centre Line 

Optical Axis 

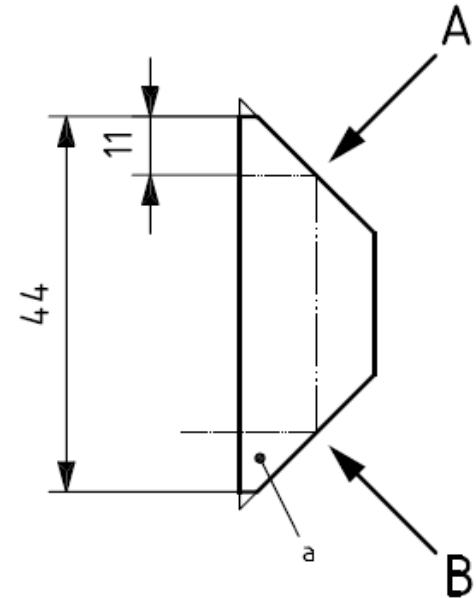

The center line is denoted by dash – dot line

The optical axis (and light path through prism) is denoted by dash-dot-dot line.

Often these are the same lines.

ISO 10110-1 Leader Lines

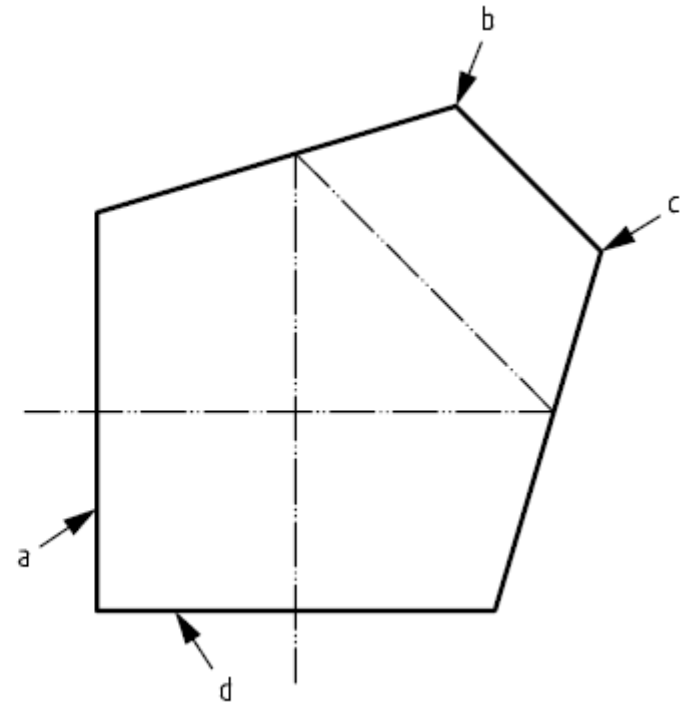
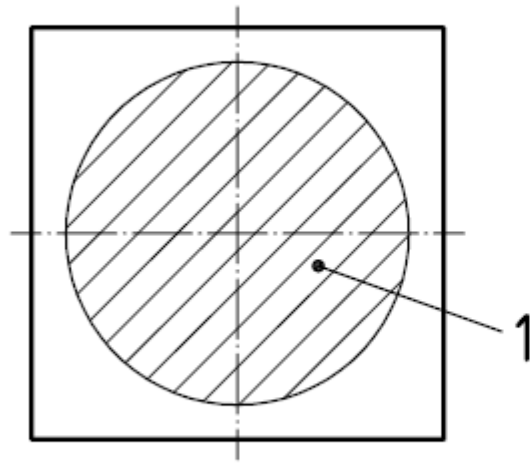

Leader lines to an area are terminated with a dot. Leader lines to a surface are terminated with an arrow.

ISO 10110-1 Test Areas

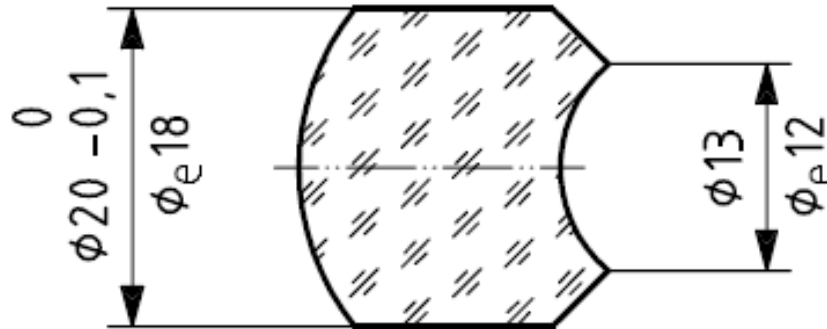

Test regions or optically effective surfaces can be denoted on the part if the entire area does not need to meet some optical requirement. The diameter of circular test regions, the “effective diameter”, is indicated by “ ϕ_e ”. It defines the region of the component surface which has optical significance.

ISO 10110-1 Dimensioning

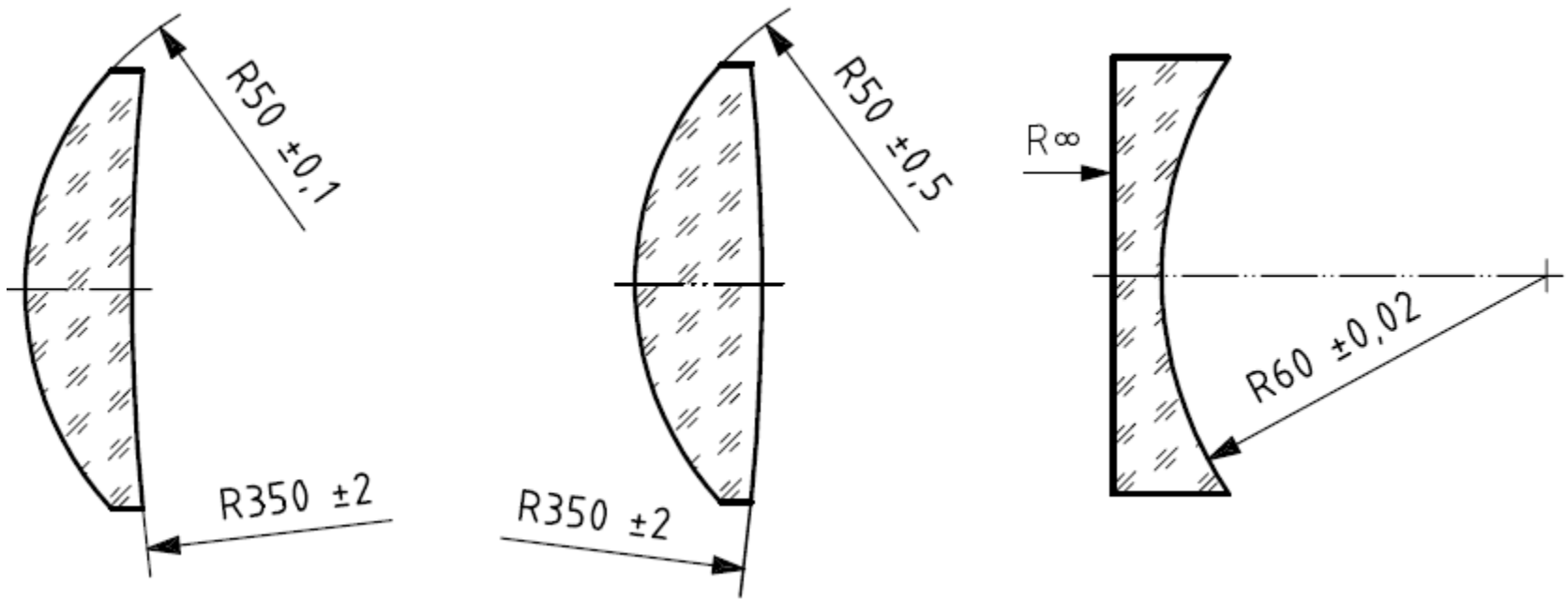

Spherical surfaces are defined by the radius of curvature with a dimensional tolerance. This tolerance indicates the range within which the actual surface is contained. The radius of curvature tolerance can also be defined by interferometry, but more on that later. For cylindrical surfaces, use R_{cyl} instead.

ISO 10110-1 Dimensioning

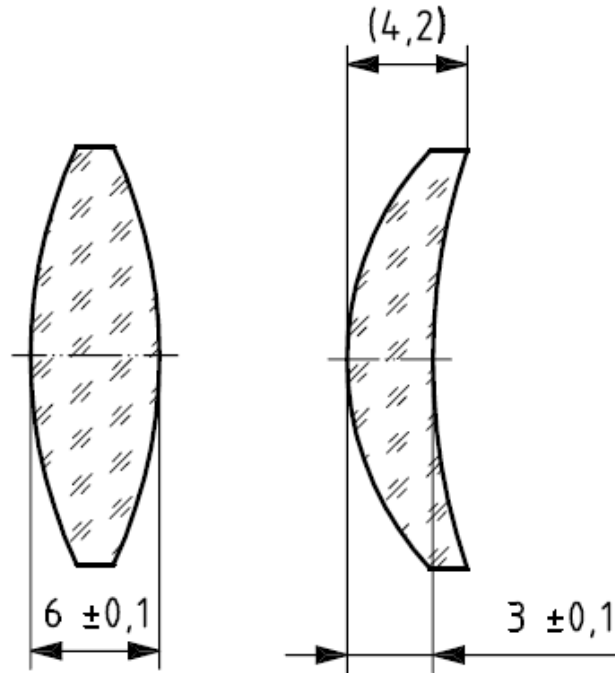

The thickness is indicated as a nominal size with a (preferably symmetrical) tolerance. In the case of lens elements having concave surfaces, the overall thickness should be indicated within parenthesis in addition to the axial thickness.

ISO 10110-1 Bevels & Chamfers

Sharp Edge

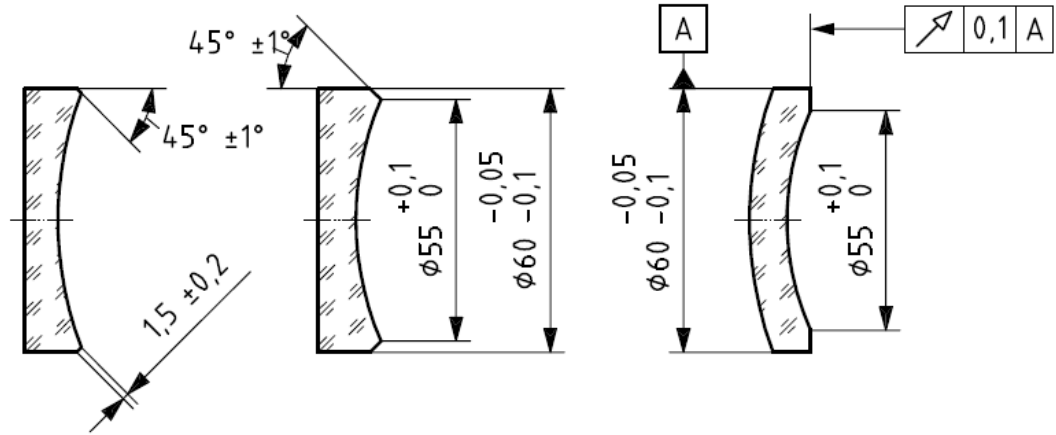
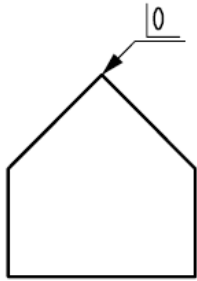

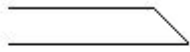
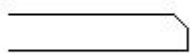
-  Bevel
-  Chamfer

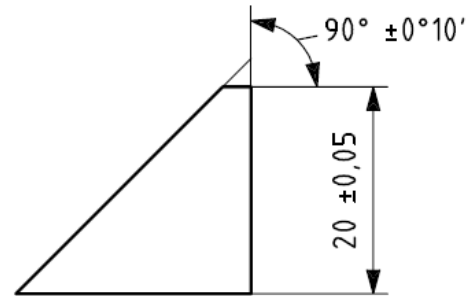

ISO 10110-1 Dimensioning

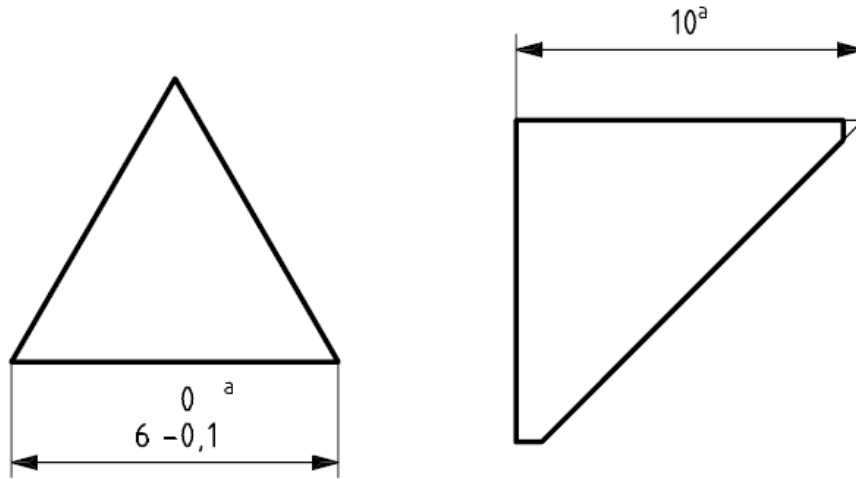

a Theor.

Parts specified to have protective chamfers or small bevels are dimensioned without regard to the chamfers or bevels, i.e. the dimensions refer to the theoretical intersection of the surfaces (“sharp edge condition”). Such dimensions shall be identified by appending “theor” to the indication.

ISO 10110-1 Angles

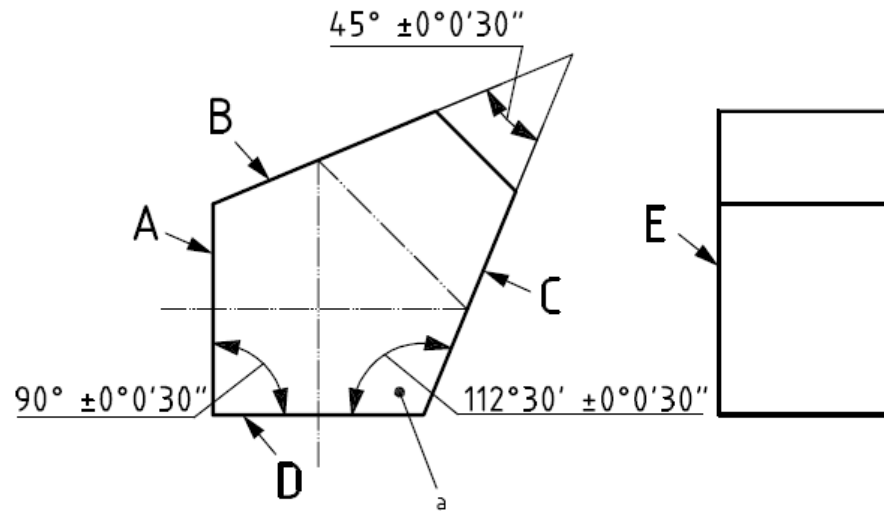

$$\sphericalangle A, E = 90^\circ \pm 0^\circ 10'$$

$$\sphericalangle D, E = 90^\circ \pm 0^\circ 10'$$

$$\sphericalangle B, E = 90^\circ \pm 0^\circ 3'$$

$$\sphericalangle C, E = 90^\circ \pm 0^\circ 3'$$

Use capital Roman letters to indicate surfaces. The angles between surface E and the surfaces A, B, C and D are called “pyramidal angles”.

ISO 10110-1 Angles

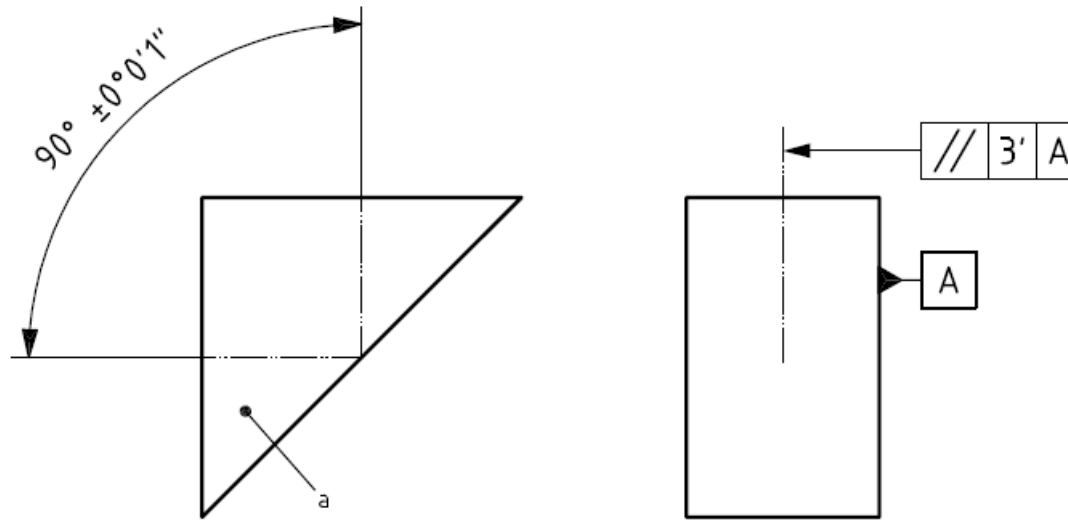

For prisms, the optical ray path and deflection angle may be shown. The deflection angle is the angle between the directions of the incident and emergent rays. Unless otherwise specified, the incident ray is perpendicular to the entrance surface. The deflection angle is given with a \pm tolerance. An error in the ray deviation in the directions perpendicular to the plane of the drawing is known as “pyramidal deviation error”.

ISO 10110-1 Materials Specs

The following information shall be given, as appropriate:

a) Indication of material, e.g.:

manufacturer, glass type

or international glass code number

or refractive index and Abbe number, including an indication of the reference wavelength

or chemical description (for example for crystalline material);

b) special properties of the material, such as:

tolerances for refractive index, dispersion, transmission, homogeneity class, striae class, crystal properties (e.g. mono- or polycrystalline)

Material data	
P3	Glass type N-BK 7
	n_d 1,51680 ±0,0005
	V_d 64,17 ±0,8%
	Q_f 10
	1_f 3x0,01
(E0,1	2_f -2

ISO 10110-2 Stress Birefringence

The stress birefringence can be visualized by placing the sample between two crossed polarizers. Glass without any stress will appear completely dark. Figure 8 shows a N-BK7 block that was placed between 2 crossed polarizers. The bright areas indicate the internal stress.



Figure 8: N-BK7 block with internal stress.

TIE-27: Stress in optical glass

SCHOTT
glass made of ideas

The cooling process can create stress within glass. This leads to polarization effects.

ISO10110-2 Stress Birefringence

The Stress Birefringence tolerance is denoted by the code 0/ followed by a number indicating the permissible OPD in nm/cm of glass path. Several example values are shown below.

Permissible optical path difference (OPD) per cm glass path	Typical applications
< 2 nm/cm	Polarisation instruments Interference instruments
5 nm/cm	Precision optics Astronomical optics
10 nm/cm	Photographic optics Microscope optics
20 nm/cm	Magnifying glasses View finder optics
Without requirement	Illumination optics

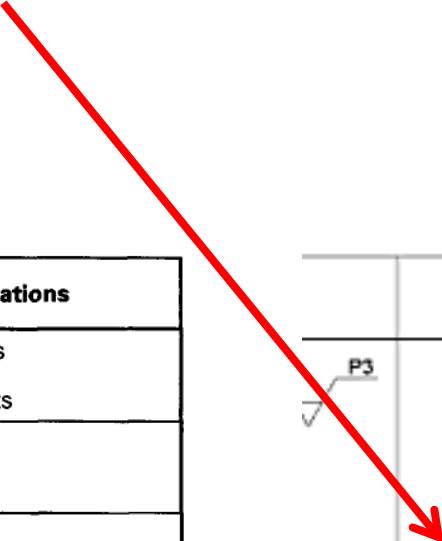

Material data	
Glass type N-BK 7	
n_d	1,51680 ±0,0005
V_d	64,17 ±0,8%
0/	10
1/	3x0,01
2/	-2

ISO 10110-3 Bubbles & Inclusions

The Bubbles and Inclusions tolerance is denoted by the code 1/ followed by N x A, where N is the maximum number of bubbles of maximal size and A is the square root of the projected area of the largest allowable bubble in mm.

A larger number of smaller bubbles is acceptable as long as the cumulative value doesn't exceed to $N \times A^2$



Material data	
P3	Glass type N-BK 7
n_d	1,51680 ±0,0005
v_d	64,17 ±0,8%
0/	10
1/	3x0,01
2/	-2

ISO 10110-4 Inhomogeneity & Striae

The Inhomogeneity and Striae tolerance is denoted by the code 2/ followed A; B, where A is the Inhomogeneity Class and B is the Striae Class.

Inhomogeneity Class

Class	Maximum permissible variation of refractive index within a part 10^{-6}
0	± 50
1	± 20
2	± 5
3	± 2
4	± 1
5	$\pm 0,5$

Striae Class

Class	Density of striae causing an optical path difference of at least 30 nm in %
1	≤ 10
2	≤ 5
3	≤ 2
4	≤ 1
5	Extremely free of striae Restriction to striae exceeding 30 nm does not apply Further information to be supplied in a note to the drawing

Material data	
	Glass type N-BK 7
n_d	1,51680 $\pm 0,0005$
v_d	64,17 $\pm 0,8\%$
Q'	10
$1'$	3x0,01
$2'$	-2

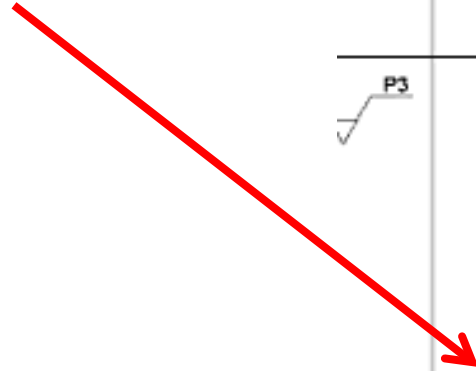
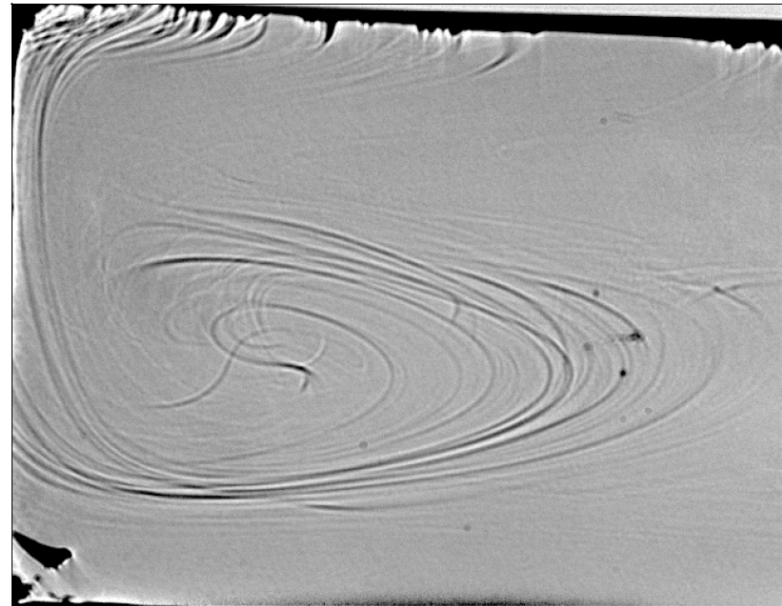

ISO10110-5 Surface Form Tolerances

Part 5 of the standard gives an alternative method for tolerancing the surface shape. Previously, we defined a tolerance on the radius of curvature of the surfaces. Surface form tolerances use Code 3/.

The indication shall have one of three forms:

3/A(B/C); $\lambda = E$

or

3/A(B/C) RMSx < D; $\lambda = E$

(where x is one of the letters t, i or a, see 3.3 of ISO 14999-4).

or

3/—RMSx < D; $\lambda = E$

(where x is one of the letters t, i or a).

Left surface	
	
R	135,991 CC
σ_e	65,3
λ	SN 1062-M400/680
3/	5(1/0,5) ←
4/	0,8 \square A
5/	3x0,16;C3x0,16;L3x0,008;E0,1

The indication "; $\lambda = E$ " (last element of the three forms of indication specified above) may be omitted provided the wavelength of specification is $\lambda = 546,07$ nm.

ISO10110-5 Surface Form Tolerances

To understand the values A, B and C and RMSx in the Surface Form Tolerance, we need to understand the wavefront shape.

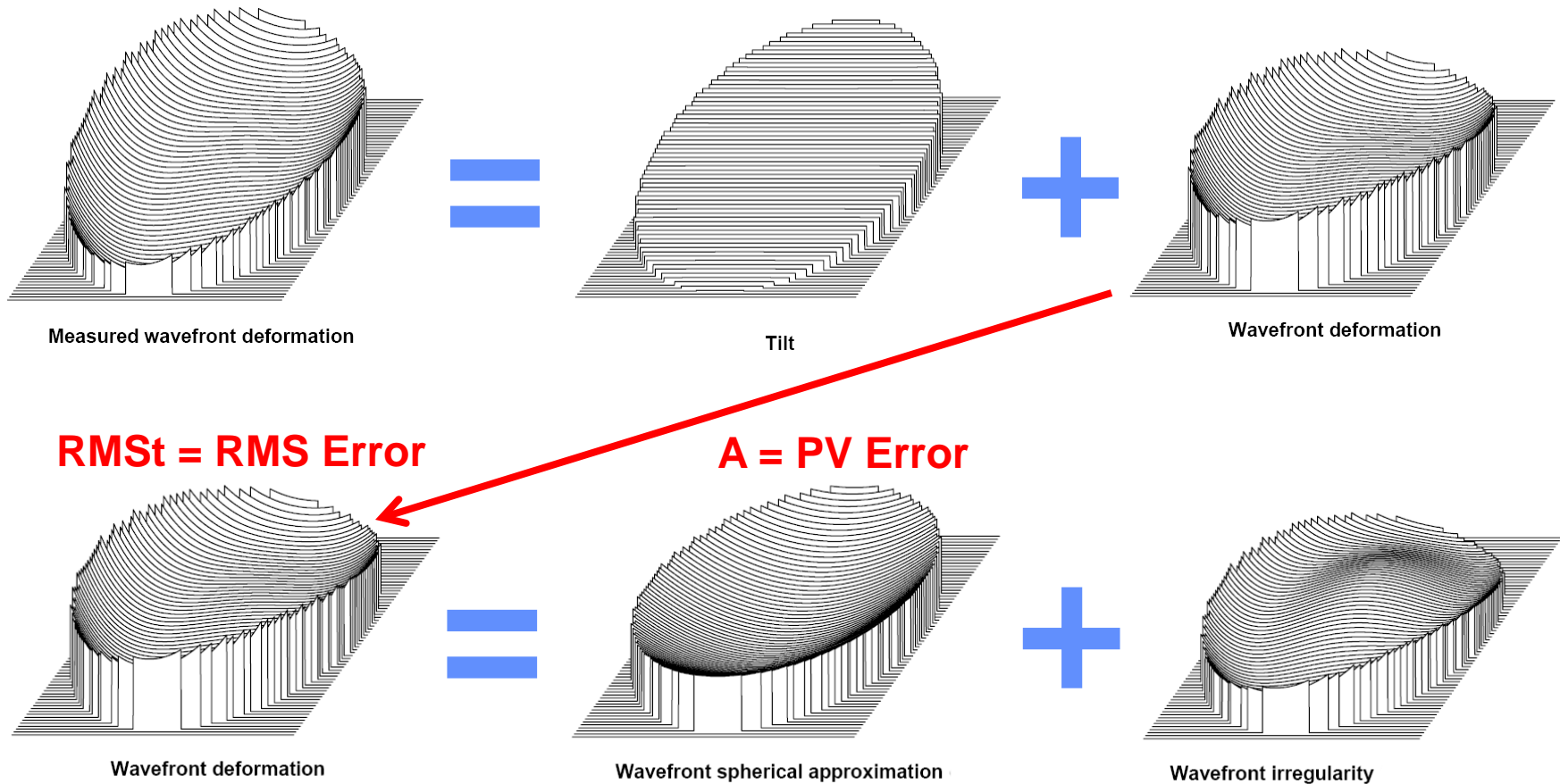

ISO10110-5 Surface Form Tolerances

We can further break down wavefront irregularity

RMS_t = RMS Error

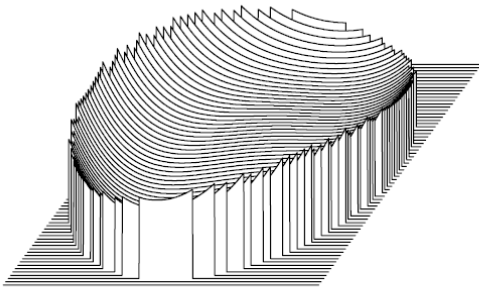

Wavefront deformation

=

A = PV Error

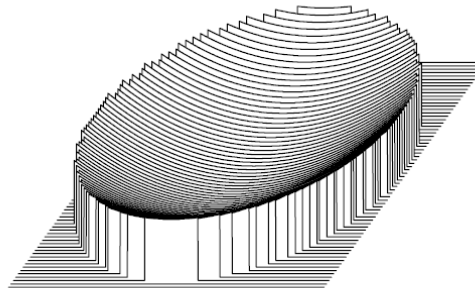

Wavefront spherical approximation

+

B = PV Error
RMS_i = RMS Error

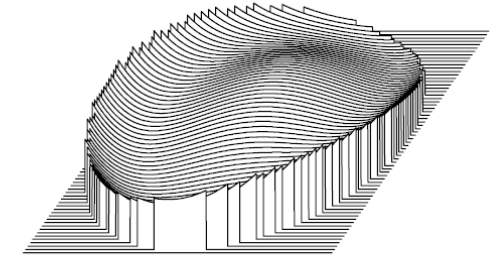

Wavefront irregularity



C = PV Error

RMS_a = RMS Error

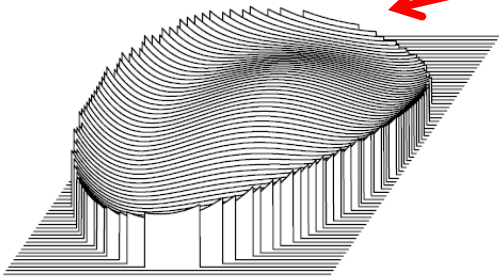

Wavefront irregularity

=

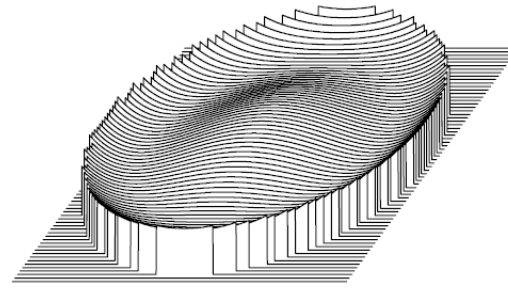

(Rotationally invariant) wavefront

+

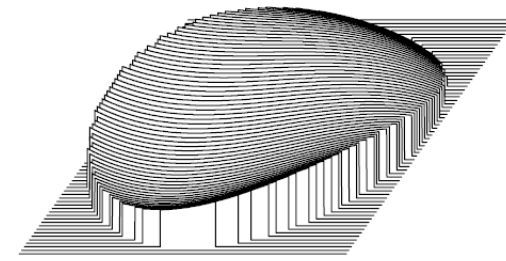

Remaining rotationally varying wavefront

ISO10110-5 Surface Form Tolerances

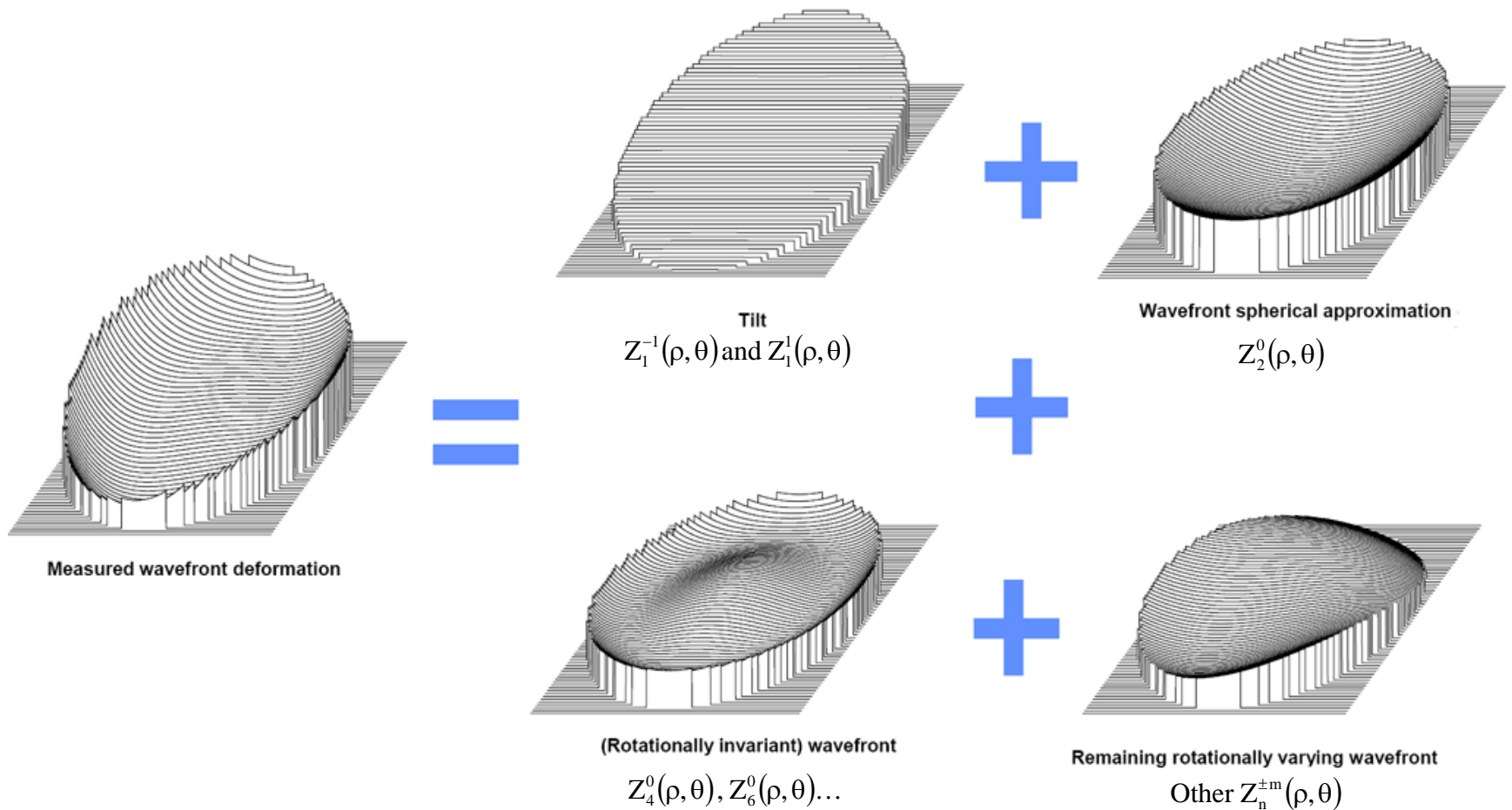

ISO10110-5 Fringe Spacings

Units for the various quantities are either given as “Fringe Spacings”, which correspond to the number of $\lambda / 2$ steps in surface deformation due to double pass or in straight surface deformation in nanometers. The wavelength is assumed to be the Mercury e-line $\lambda = 546.07$ nm unless otherwise specified.

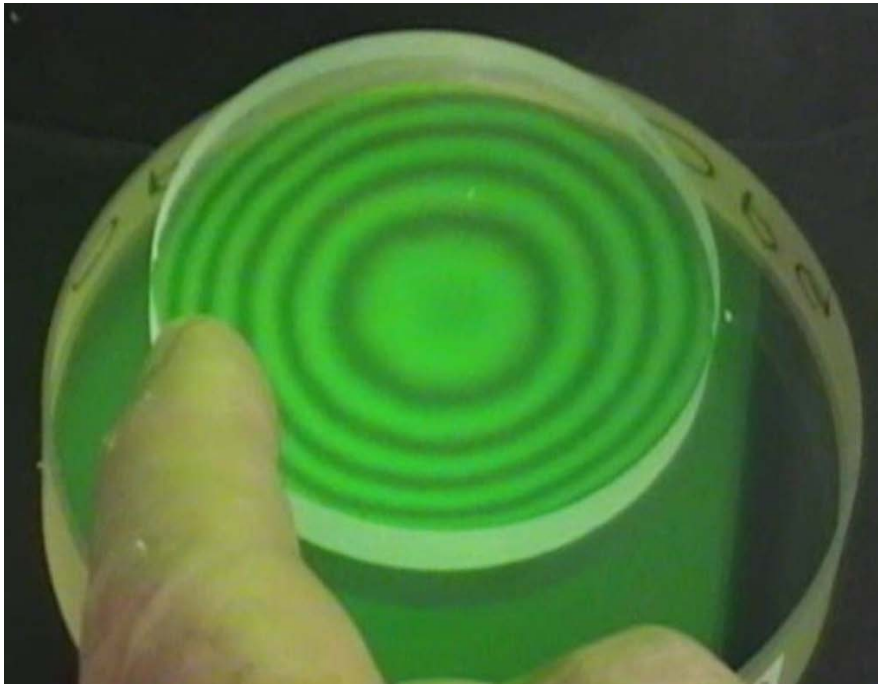

The picture shows approximately 5 fringe spacings which corresponds to a $5(546.07 \text{ nm}) / 2 = 1.365 \mu\text{m}$ gap between the part and test plate at the edge of the part.

ISO 10110-5 Surface Form Tolerances Examples

EXAMPLE 1

3/3(1)

The tolerance for sagitta deviation is 3 fringe spacings. The irregularity may not exceed 1 fringe spacing.

EXAMPLE 2

3/5(—) RMSi < 0,05

The tolerance for sagitta deviation is 5 fringe spacings. No specific tolerance is given for irregularity or rotationally invariant irregularity, but the rms value of the irregularity may not exceed 0,05 fringe spacings.

EXAMPLE 3

3/3(1/0,5); $\lambda = 632,8 \text{ nm}$ (all $\varnothing 20$)

The tolerance for sagitta deviation is 3 fringe spacings. The total irregularity may not exceed 1 fringe spacing. The rotationally symmetric irregularity may not exceed 0,5 fringe spacings. These tolerances apply for all possible test fields of diameter 20 mm within the total test area. The wavelength for all surface form deviation specifications is $\lambda = 632,8 \text{ nm}$.

NOTE In case of nanometre indication: 3/ 949,4 nm (316,4 nm/158,2 nm) (all $\varnothing 20$)

ISO 10110-5 Surface Form Tolerances Examples

EXAMPLE 4

3/—(1)

No specific tolerance for sagitta deviation is given; the tolerance on the radius of curvature is to be taken from the radius of curvature indication. The total irregularity may not exceed 1 fringe spacing.

NOTE If no tolerance on the radius of curvature is specified, then ISO 10110-11:1996, table 1, applies.

EXAMPLE 5

3/—RMSt < 0,07; RMSa < 0,035; $\lambda = 405 \text{ nm}$

No specific tolerance for sagitta deviation, irregularity, or rotationally invariant irregularity is given; the tolerance on the radius of curvature is to be taken from the radius of curvature indication; however, when the surface is compared with the desired theoretical surface, the rms total shall be less than 0,07 fringe spacings, and the rms asymmetric irregularity less than 0,035 fringe spacings.

NOTE If no tolerance on the radius of curvature is specified, then ISO 10110-11:1996, table 1, applies.

EXAMPLE 6

3/ 600 nm (300 nm/150 nm) (all $\varnothing 20$)  Add this to specify a sub-aperture in ϕ_e

The tolerance for sagitta deviation is 600 nm. The total irregularity shall be less than 300 nm. The rotationally invariant irregularity shall be less than 150 nm. These tolerances apply for all possible test fields of diameter 20 mm within the total test area.

ISO 10110-6 Centring Tolerances

Part 6 describes tilt and decentration tolerances and is specified by code 4/. Units are arcmin and/or arcsec for angles and mm for decentration.

4/ σ

or

4/ $\sigma(L)$

or

4/ $\Delta\tau$

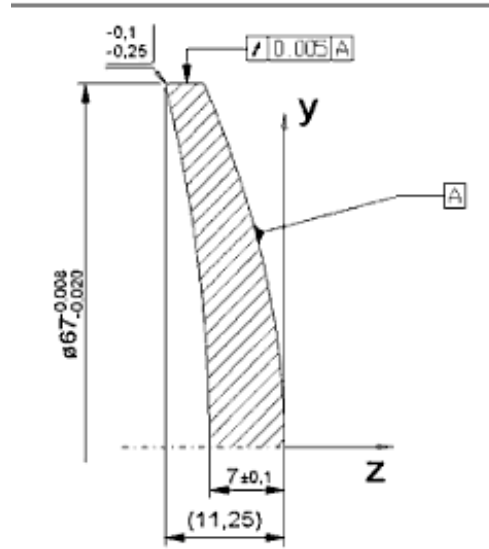

Left surface	
R	135.001 CC
ϕ_e	65,3
λ	SN 1062-M400/680
3/	5(1/0,5)
4/	0,8 [A] ←
5/	3x0,16;C3x0,16;L3x0,008;E0,1

where σ is the maximum permissible tilt angle, L is the maximum permissible lateral displacement, and τ (following the delta symbol Δ), is the maximum permissible cement wedge angle.

ISO 10110-6 Centring Tolerances

“Datum Axes” need to be defined. Angles σ or distances L are measured relative to these axes.

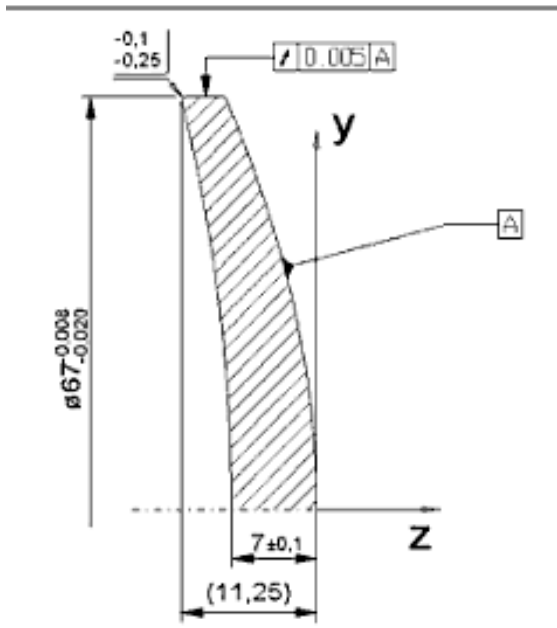

Use leaders with a triangle on the end and t letter to specify a datum feature. These features help define the data axes.

Here A refers to an aspheric surface defining a datum axis which corresponds to the axis of symmetry of the asphere.

ISO 10110-6 Centring Tolerances

Other examples of Datum Axes are shown below. Use  for a point on the datum axis if needed.

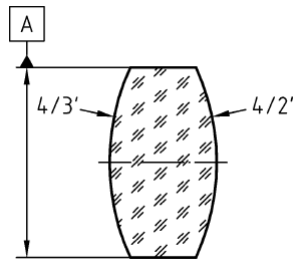

Here A refers to the outer cylinder of the lens. The datum axis becomes the axis of the cylinder.

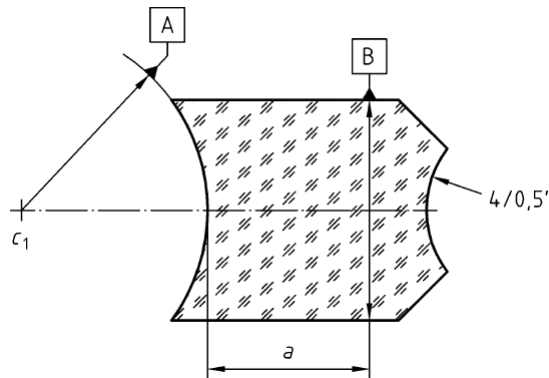

Here A refers to the center of curvature of the first surface and B refers to the cylinder located a distance a away. The datum axis becomes the axis connecting c_1 to the center of the cylinder B.

ISO 10110-7 Surface Imperfections

Part 7 describes surface imperfection tolerances. Examples of these are scratches, scuffs, coating blemishes and edge chips. Code 5/ is used to specify these factors for a surface and 15/ for assemblies.

5 or 15/ $N \times A$; $CN' \times A'$; $LN'' \times A''$; EA'''

To summarise:

- 5/ represents surface imperfections and 15/ respectively;
- $N \times A$ for surface imperfections; Number x Sqrt(Area in mm)
- $CN' \times A'$ for coating blemishes; Number x Sqrt(Area in mm)
- $LN'' \times A''$ for long scratches; Number x width in mm
- EA''' for edge chips. Sqrt(Area in mm)

Left surface	
	P3
R	135,001 CC
ϕ_e	65,3
λ	SN 1062-M400/880
3/	5(1/0,5)
4/	0,8 A
5/	3x0,16;C3x0,16;L3x0,008;E0,1

ISO 10110-8 Surface Texture

Part 8 describes surface texture tolerances. There are Matte (Ground) surfaces where the rms surface roughness is $\gg \lambda$, and Smooth (Polished or molded) surfaces where the rms surface roughness is $< \lambda$.

These features are denoted on the drawings by a labeled “checkmark”. The checkmark can be in the surface description or on the actual drawing.

Left surface	
R	135,001 CC
σ_e	65,3
λ	SN 1062-M400/680
3/	5(1/0,5)
4/	0,8 [A]
5/	3x0,16;C3x0,16;L3x0,008;E0,1



A red arrow points from the right side of the table to the checkmark symbol.

ISO 10110-8 Surface Texture

Matte surfaces are denoted with a G (Ground)
Rq is the rms surface roughness

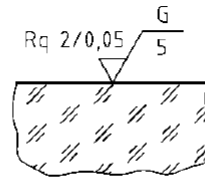

Figure 1 — Indication for ground surface with $2 \mu\text{m} > Rq > 0,05 \mu\text{m}$ and minimum sampling length of 5 mm

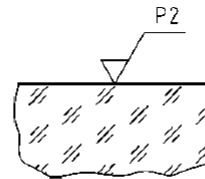

Figure 3 — Indication for smooth surface with < 80 microdefects per 10 mm linear scan of the surface

Table A.1

Polishing grade designation	Number N of microdefects per 10 mm of sampling length
P1	$80 < N < 400$
P2	$16 < N < 80$
P3	$3 < N < 16$
P4	$N < 3$

ISO 10110-9 Surface Treatments and Coatings

Part 9 describes surface treatments such as protective coatings or paint, as well as optical coatings such as AR and mirror.

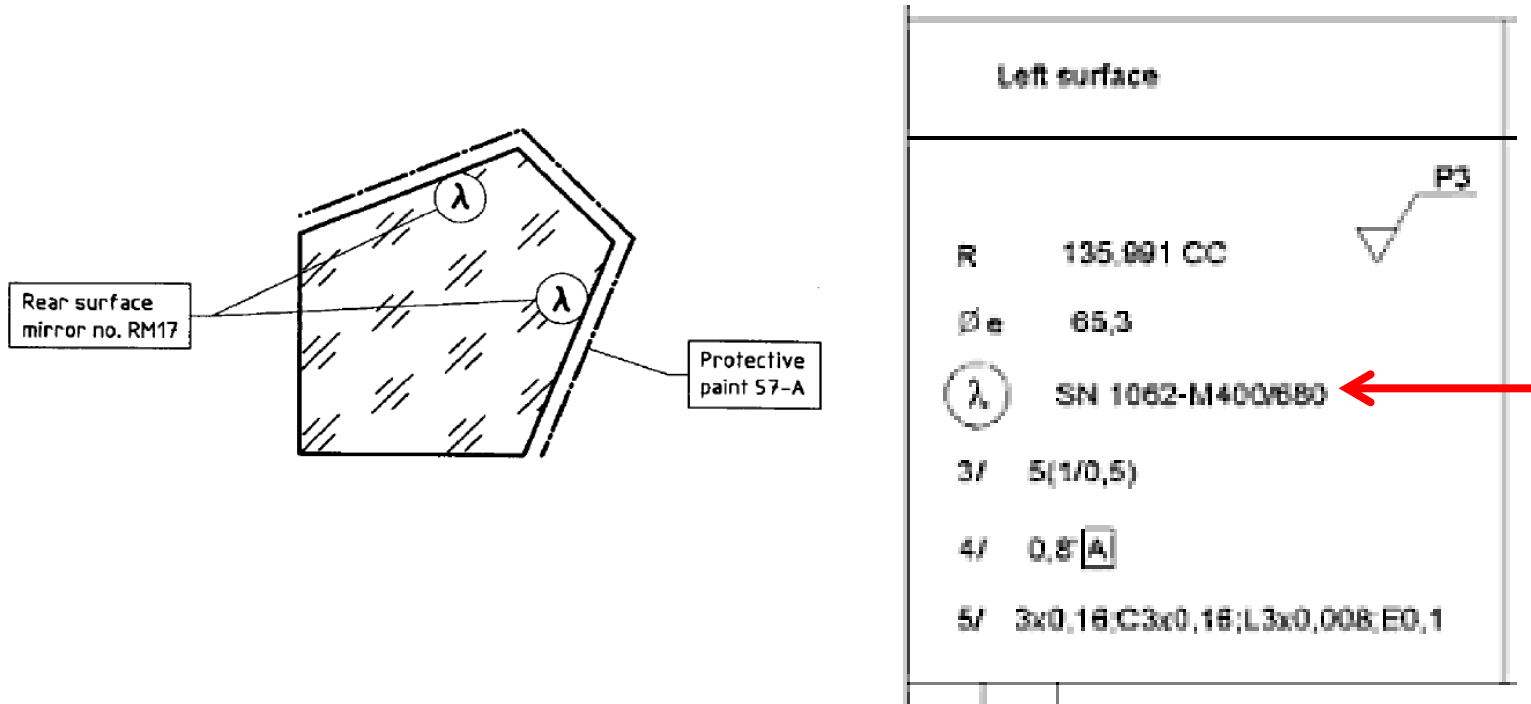

ISO 10110-10 Tabular Format

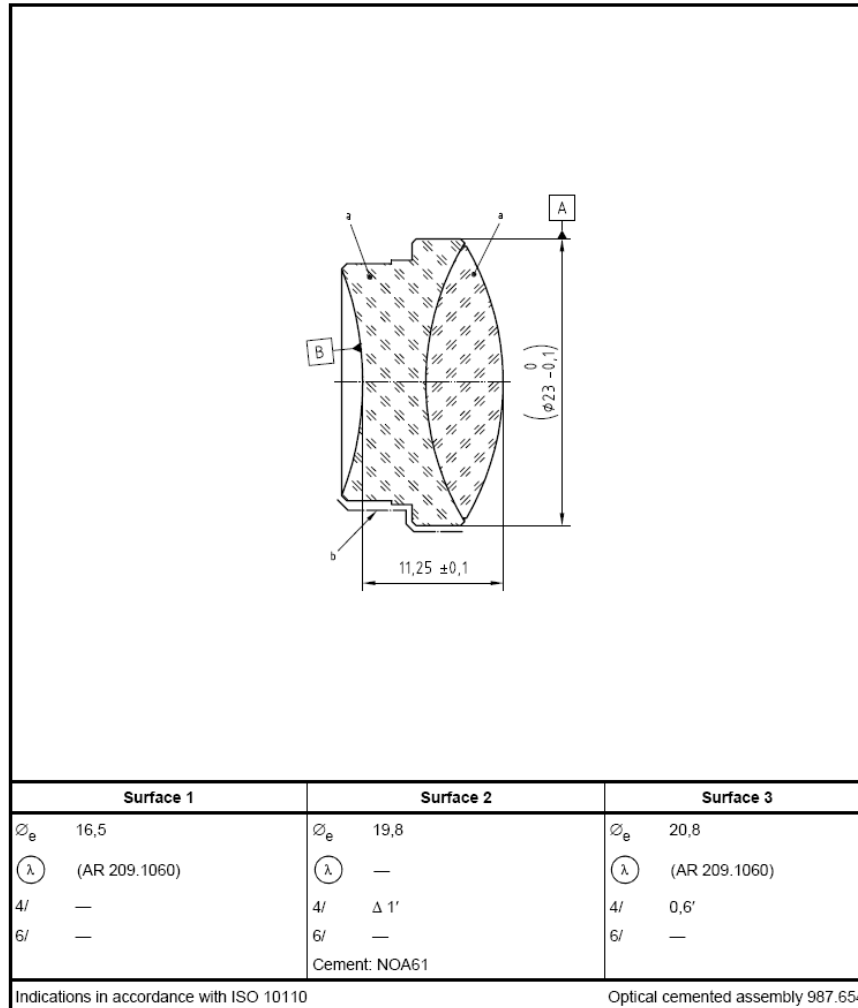

ISO 10110-11 Default Specs

Table 1 — Permissible deviations and material imperfections in case explicit indications are not given

Property	Range of maximum (diagonal) dimension of the part mm			
	up to 10	over 10 up to 30	over 30 up to 100	over 100 up to 300
Edge length, diameter (mm)	± 0,2	± 0,5	± 1	± 1,5
Thickness (mm)	± 0,1	± 0,2	± 0,4	± 0,8
Angle deviation of prisms and plate	± 0° 30'	± 0° 30'	± 0° 30'	± 0° 30'
Width of protective chamfer (mm)	0,1 to 0,3	0,2 to 0,5	0,3 to 0,8	0,5 to 1,6
Stress birefringence in accordance with ISO 10110-2 (nm/cm)	0/20	0/20	—	—
Bubbles and inclusions in accordance with ISO 10110-3	1/3 × 0,16	1/5 × 0,25	1/5 × 0,4	1/5 × 0,63
Inhomogeneity and striae in accordance with ISO 10110-4	2/1;1	2/1;1	—	—
Surface form tolerances in accordance with ISO 10110-5	3/5(1)	3/10(2)	3/10(2) (all Ø 30)	3/10(2) (all Ø 60)
Centring tolerances in accordance with ISO 10110-6	4/30'	4/20'	4/10'	4/10'
Surface imperfection tolerances in accordance with ISO 10110-7	5/3 × 0,16	5/5 × 0,25	5/5 × 0,4	5/5 × 0,63
Key				
—: No specification				

ISO 10110-12 Aspheric Surfaces

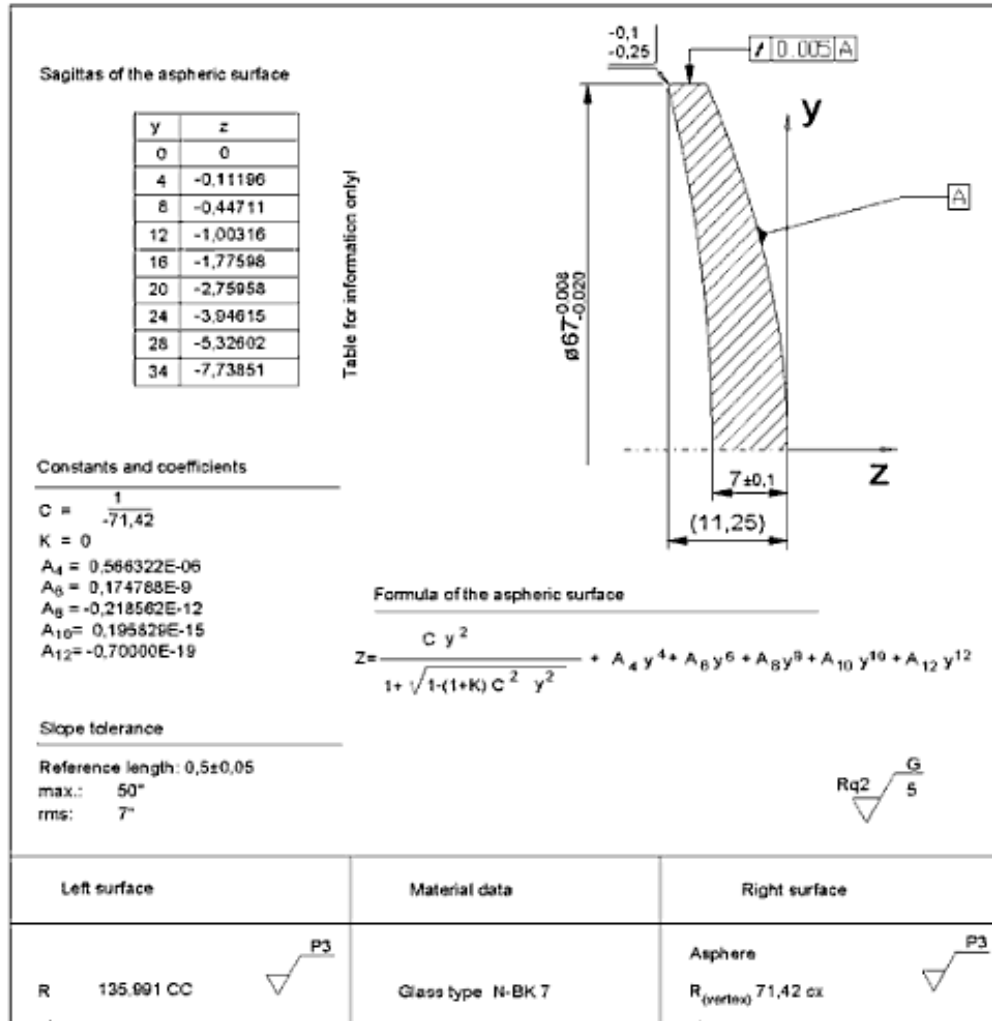

ISO 10110-14 Wavefront Deformation

ISO 10110-17 Laser Damage Thresholds